

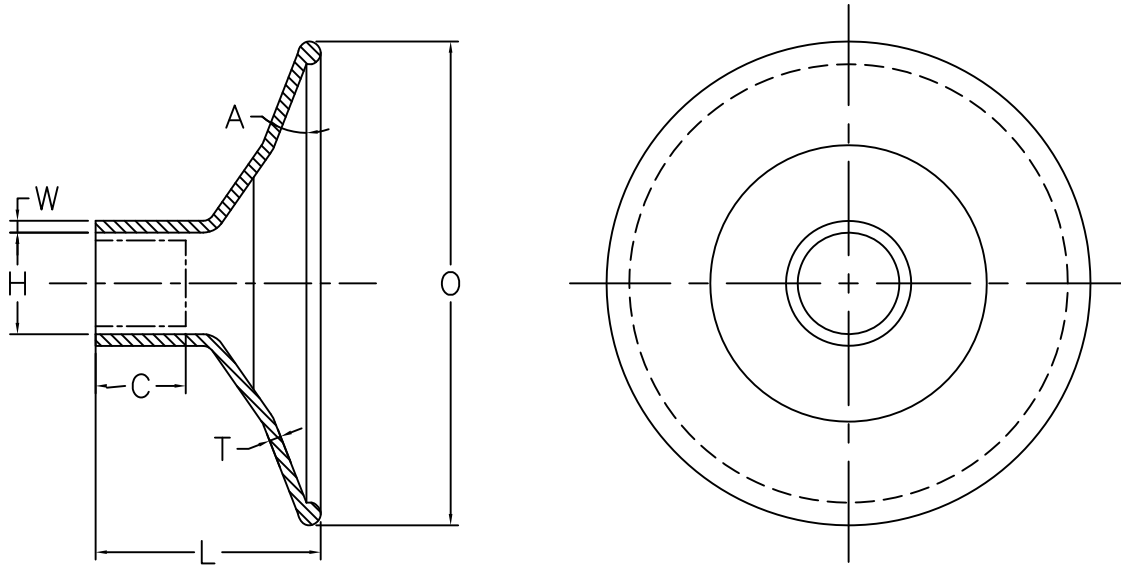

PRODUCT	HV SHEDS
MODEL	IXL 215,225,235&245
DOCUMENT NO.	DR/MFG/200
PAGE	2 OF 2



HV SHEDS DESIGN

MODEL	H	EXP-H	O	L	W	T	C	A
	S	E	S	S	S	S	E	S
IXL 215	12.00	37.00	90.00	45.00	3.50	2.50	20.00	15°
IXL 225	16.00	57.00	115.00	55.00	4.00	3.00	25.00	25°
IXL 235	25.00	75.00	140.00	68.00	4.00	3.50	25.00	25°
IXL 245	35.00	100.00	200.00	90.00	4.00	4.00	40.00	25°

E : DIMENSION WHEN EXPANDED

S : DIMENSION WHEN FULLY RECOVERED

NOTES

1. ALL DIMENSIONS ARE IN MM.

2. TOLERANCES :

THICKNESS	W,T	± 10%
LENGTHS	L	± 10%
DIAMETERS	H,O	± 5%
ANGLES	A	± 5%

REVISION NO.	6	FIRST ANGLE PROJECTION	SCALE : NTS	ALL DIMENSIONS IN MM.
DATE	16/01/21	DRAWN BY : Wanathaphong	APPROVED BY :	SANJEEV NABAR